

ALUMINUM 3 1/4" FRAME STACK MULLIONS

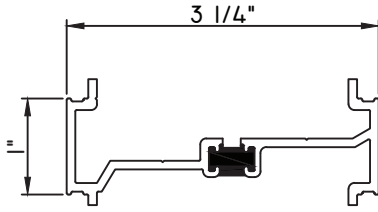

1" STACK MULL
M537248 - STACK MULL
970-300 - WEEP COVER

FIELD APPLIED INSTALL ONLY

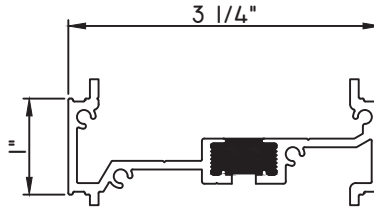

1" STACK MULL
M23723 - STACK MULL
970-300 - WEEP COVER
QWP-M23846 - END DAM (QTY. 2)
QWP-M23845 - END DAM (QTY. 2)
BRBTT46 - POP RIVET (QTY. 8)

FIELD APPLIED INSTALL ONLY

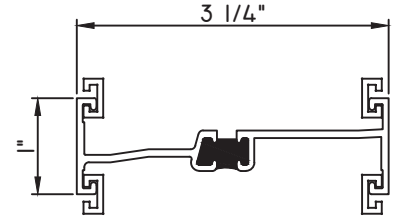

1" STACK MULL
M21087 - STACK MULL
M6270 - C-MULL (QTY. 2 OR 4)
970-300 - WEEP COVER

FACTORY APPLIED INSTALL ONLY

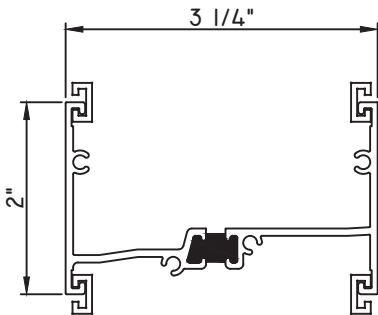

2" STACK MULL
M16318 - STACK MULL
M6270 - C-MULL (QTY. 2 OR 4)
72406 - END DAM (QTY. 2)
BRBTT46 - POP RIVET (QTY. 8)
970-300 - WEEP COVER

FACTORY APPLIED INSTALL ONLY

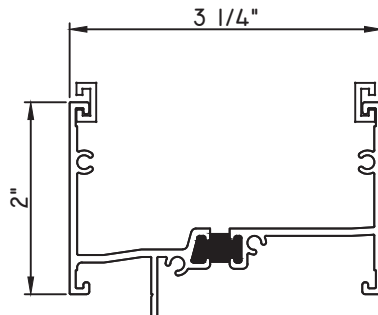

2" STACK MULL
M17032 - STACK MULL
M6270 - C-MULL (QTY. 2)
72406 - END DAM (QTY. 2)
BRBTT46 - POP RIVET (QTY. 8)
970-300 - WEEP COVER

FACTORY APPLIED INSTALL ONLY

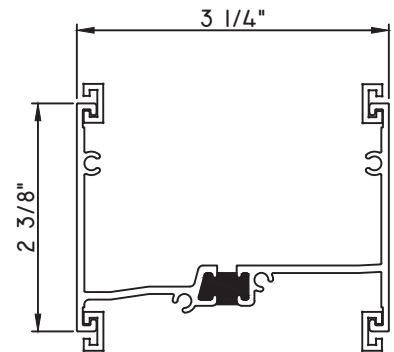

2 3/8" STACK MULL
M22015 - STACK MULL
M6270 - C-MULL (QTY. 2 OR 4)
QWP-032917 - END DAM (QTY. 2)
BRBTT46 - POP RIVET (QTY. 8)
970-300 - WEEP COVER

FACTORY APPLIED INSTALL ONLY

SCALE 1:2

ALUMINUM 3 1/4" FRAME STACK MULLIONS

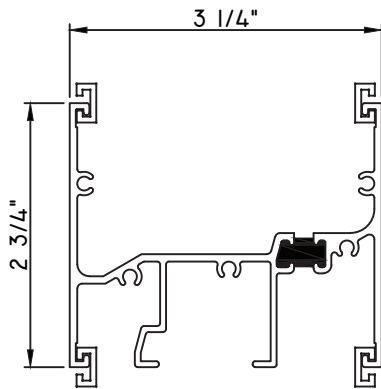

2 3/4" STACK MULL

M15731 - STACK MULL
M6270 - C-MULL (QTY. 2 OR 4)
- END DAM (QTY. 2)
BRBTT46 - POP RIVET (QTY. 8)
970-300 - WEEP COVER

FACTORY APPLIED INSTALL ONLY

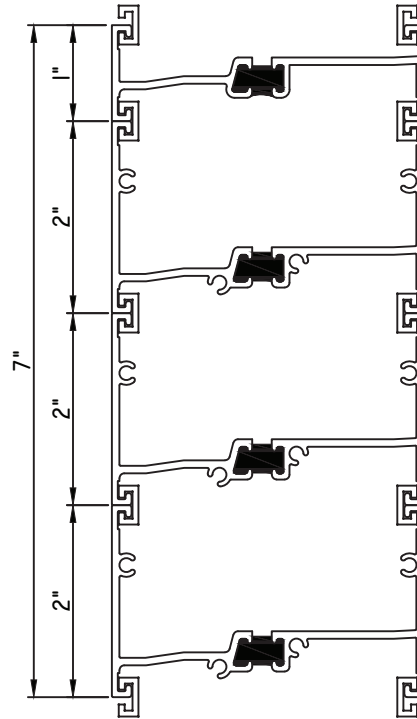

7" STACK MULL

M16318 x3 - STACK MULL
M6270 - C-MULL (QTY. 2 OR 4)
72406 - END DAM (QTY. 2)
BRBTT46 - POP RIVET (QTY. 8)
970-300 - WEEP COVER

FACTORY APPLIED INSTALL ONLY

SCALE 1:2

ALUMINUM 3 1/4" FRAME VERTICAL MULLIONS

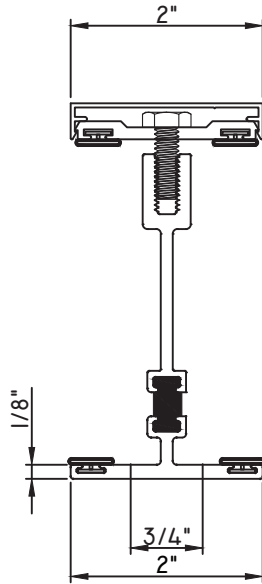
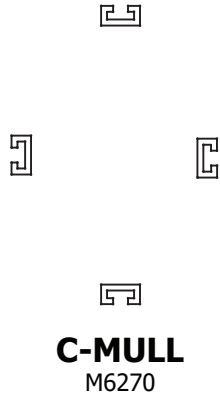

T-MULL

M16875 - T-MULL
MAX17386 - BASE
MAX14141 - CAP
BPN-9159 - W.S. (QTY. 4)
MH1/4 20X3/4 - BOLTS (18" APROX. O.C.)
M13404 - L-ANGLE (QTY. 2)
MPS-8X1 1/2 - FASTENERS (QTY. 4)

**MUST BE USED WITH STANDARD
3 1/4" RECEPTOR & SUBSILLS**

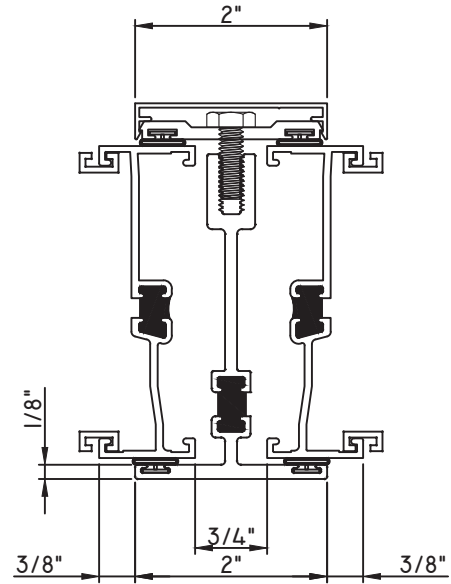

T-MULL/1" STACK MULL LEFT/RIGHT

M16875 - T-MULL
MAX17386 - BASE
MAX14141 - CAP
M21087 - 1" STACK MULL LEFT/RIGHT

SCALE 1:2

ALUMINUM 3 1/4" FRAME VERTICAL MULLIONS

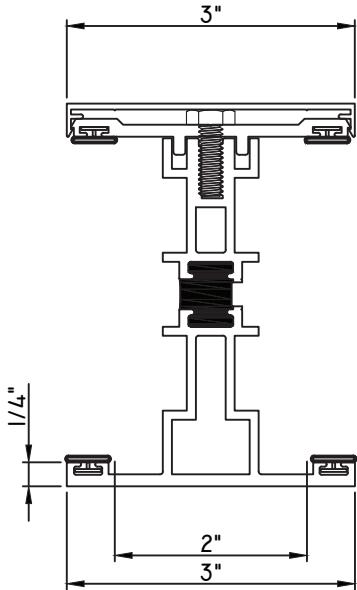

HEAVY WALL T-MULL

- M21045 - T-MULL
- M21043 - BASE
- M21044 - CAP
- BPN-9159 - W.S. (QTY. 4)
- MH1/4 20X3/4 - BOLTS (18" APROX. O.C.)
- M13404 - L-ANGLE (QTY. 2)
- MPS-8X1 1/2 - FASTENERS (QTY. 4)

**MUST BE USED WITH HEAVY WALL
3 1/4" RECEPTOR & SUBSILLS**

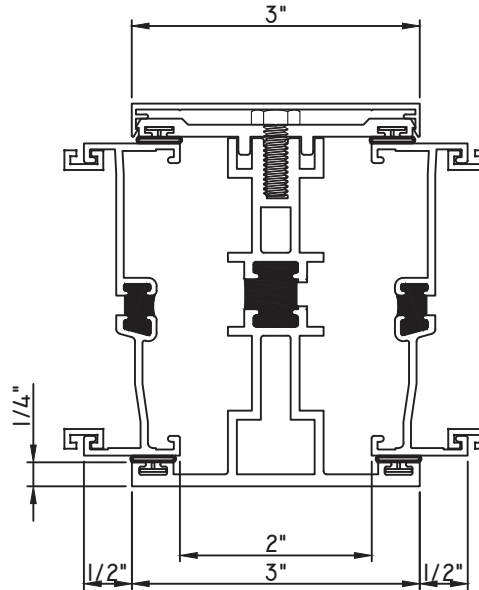

HEAVY WALL T-MULL/1" STACK MULL LEFT/RIGHT

- M21045 - T-MULL
- M21043 - BASE
- M21044 - CAP
- M21087 - 1" STACK MULL LEFT/RIGHT

SCALE 1:2

ALUMINUM 3 1/4" FRAME VERTICAL MULLIONS



BULLNOSE T-MULL W/ 1 1/4" INTERIOR CAP

M21086 - T-MULL
M14895 - BASE
M14896 - CAP
BPN-9159 - W.S. (QTY. 4)
MH1/4 20X3/4 - BOLTS (18" APPROX. O.C.)
M13404 - L-ANGLE (QTY. 2)
MPS-8X1 1/2 - FASTENERS (QTY. 4)

**CAN'T BE USED WITH RECEPTOR &
SUBSILL INSTALLATION**

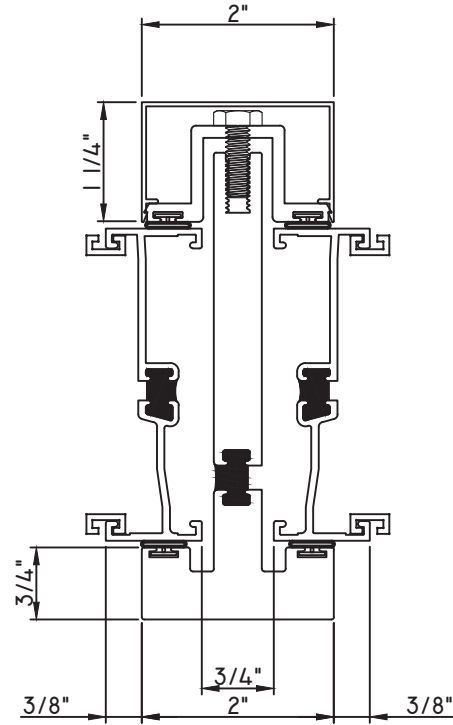

BULLNOSE T-MULL W/ 1 1/4" INTERIOR CAP /1" STACK MULL LEFT/RIGHT

M21086 - T-MULL
M14895 - BASE
M14896 - CAP
M21087 - 1" STACK MULL LEFT/RIGHT
**CAN'T BE USED WITH RECEPTOR &
SUBSILL INSTALLATION**

SCALE 1:2

ALUMINUM 3 1/4" FRAME VERTICAL MULLIONS

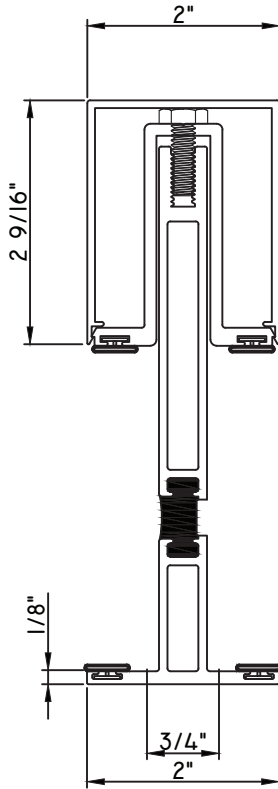

T-MULL W/ 2 9/16" INTERIOR CAP

- M21856 - T-MULL
- M21855 - BASE
- M21854 - CAP
- BPN-9159 - W.S. (QTY. 4)
- MH1/4 20X3/4 - BOLTS (18" APROX. O.C.)
- M13404 - L-ANGLE (QTY. 2)
- MPS-8X1 1/2 - FASTENERS (QTY. 4)

**MUST BE USED WITH STANDARD
3 1/4" RECEPTOR & SUBSILLS**

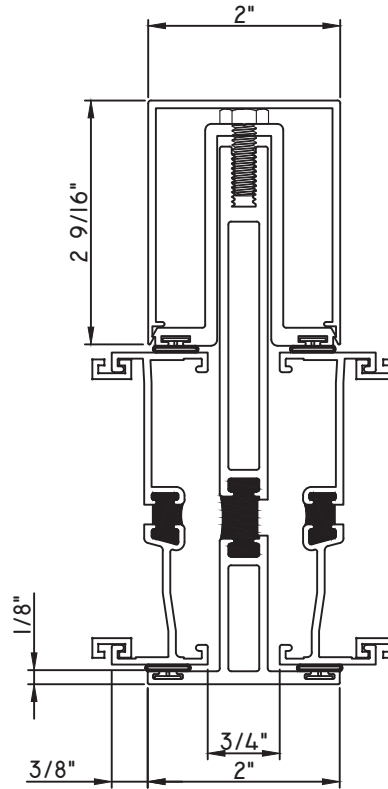

T-MULL W/ 2 9/16" INTERIOR CAP/ 1" STACK MULL LEFT

- M21856 - T-MULL
 - M21855 - BASE
 - M21854 - CAP
 - M21087 - 1" STACK MULL LEFT
- MUST BE USED WITH STANDARD
3 1/4" RECEPTOR & SUBSILLS**

SCALE 1:2



ALUMINUM 3 1/4" FRAME VERTICAL MULLIONS

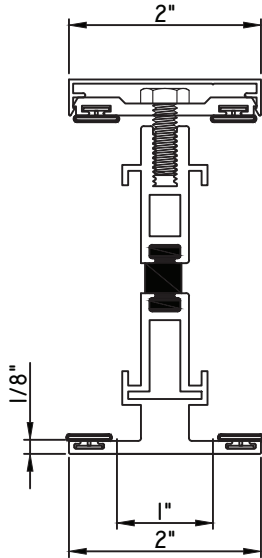

T-MULL

- M22126 - T-MULL
- MAX17386 - BASE
- MAX14141 - CAP
- BPN-9159 - W.S. (QTY. 4)
- MH1/4 20X3/4 - BOLTS (18" APROX. O.C.)
- PARTS FOR NON NAIL FIN INSTALL:
- M13404 - L-ANGLE (QTY. 2)
- MPS-8X1 1/2 - FASTENERS (QTY. 4)
- PARTS FOR NAIL FIN INSTALL:
- M22127 - Z-CLIP (QTY. 2)
- M23616 - H450 Z-CLIP (QTY. 2)

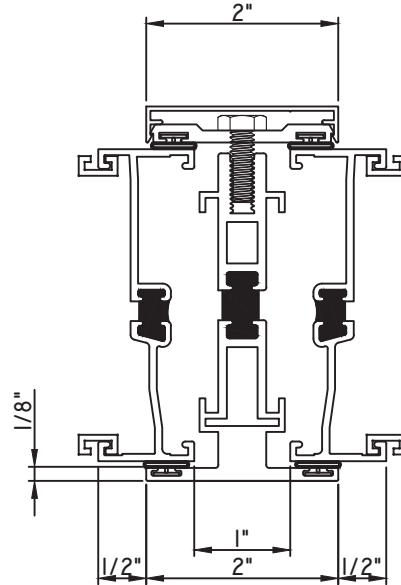

T-MULL/1" STACK MULL LEFT/RIGHT

- M22126 - T-MULL
- MAX17386 - BASE
- MAX14141 - CAP
- M21087 - 1" STACK MULL LEFT/RIGHT

**MUST BE USED WITH STANDARD
3 1/4" RECEPTOR & SUBSILLS**

SCALE 1:2

Our products are tested to the standards of and certified by some of the foremost organizations in the fenestration industry.



ALUMINUM 3 1/4" FRAME VERTICAL MULLIONS

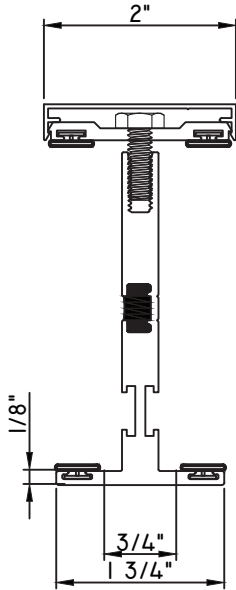

T-MULL

- M24628 - T-MULL
- MAX17386 - BASE
- MAX14141 - CAP
- BPN-9159 - W.S. (QTY. 4)
- MH1/4 20X3/4 - BOLTS (18" APROX. O.C.)
- PARTS FOR NON NAIL FIN INSTALL:
- M13404 - L-ANGLE (QTY. 2)
- MPS-8X1 1/2 - FASTENERS (QTY. 4)
- PARTS FOR NAIL FIN INSTALL:
- M22127 - Z-CLIP (QTY. 2)
- M23616 - H450 Z-CLIP (QTY. 2)

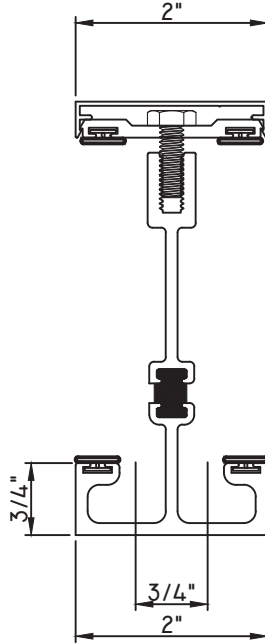

T-MULL

- M536203 - T-MULL
- M17386 - BASE
- MAX14141 - CAP
- BPN-9159 - W.S. (QTY. 4)
- MH1/4 20X3/4 - BOLTS (18" APROX. O.C.)
- M13404 - L-ANGLE (QTY. 2)
- MPS-8X1 1/2 - FASTENERS (QTY. 4)

**MUST BE USED WITH STANDARD
2 3/8" RECEPTOR & SUBSILL**

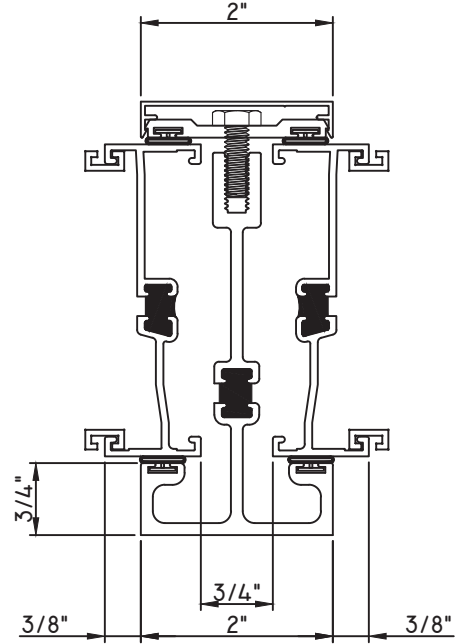

**T-MULL/1" STACK MULL
LEFT/RIGHT**

- M536203 - T-MULL
- M17386 - BASE
- MAX14141 - CAP
- M21087 - 1" STACK MULL LEFT/RIGHT
- MUST BE USED WITH STANDARD
2 3/8" RECEPTOR & SUBSILL**

SCALE 1:2

ALUMINUM 3 1/4" FRAME VERTICAL MULLIONS

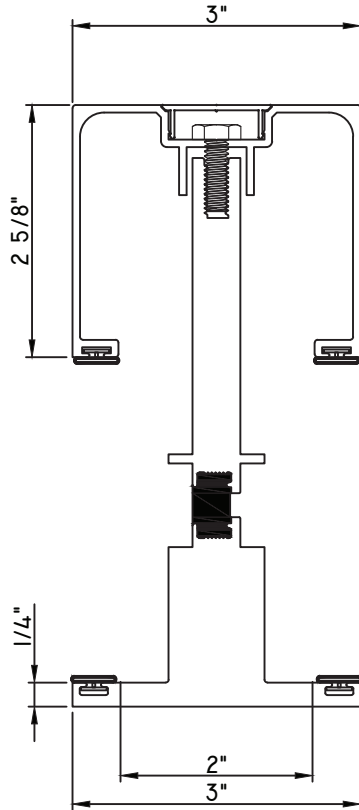

T-MULL

M23980 - T-MULL
M23981 - BASE
M536207 - CAP
BPN-9159 - W.S. (QTY. 4)
MH1/4 20X3/4 - BOLTS (18" APROX. O.C.)
M13404 - L-ANGLE (QTY. 2)
MPS-8X1 1/2 - FASTENERS (QTY. 4)

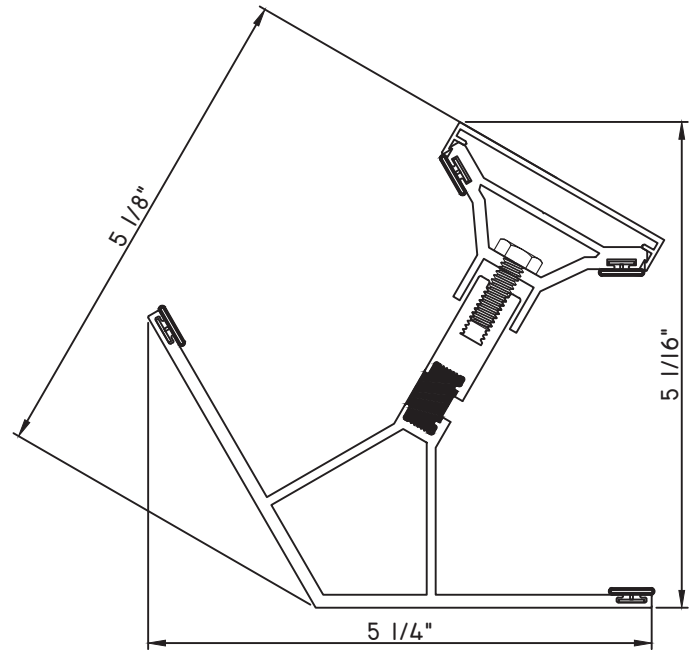

120° T-MULL

23916 - T-MULL
23917 - BASE
23918 - CAP
BPN-9159 - W.S. (QTY. 4)
MH1/4 20X3/4 - BOLTS (18" APROX. O.C.)
MPS-8X1 1/2 - FASTENERS (QTY. 4)

SCALE 1:2



ALUMINUM 3 1/4" FRAME VERTICAL MULLIONS

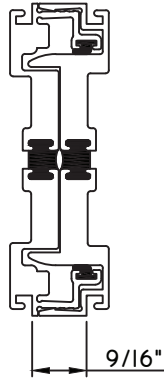

9/16" HEAVY WALL MALE/FEMALE MULL

- M22026 - MALE MULL
- M22025 - FEMALE MULL
- U4512-00000 - MALE MULL W.S. (QTY. 2)

**MUST BE USED WITH RECEPTOR &
SUBSILL INSTALLATION**

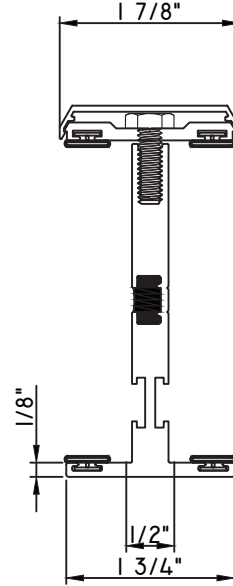

T-MULL

- M24628 - T-MULL
- M23056 - BASE
- M23058 - CAP
- BPN-9159 - W.S. (QTY. 4)
- MH1/4 20X3/4 - BOLTS (18" APROX. O.C.)
- PARTS FOR NON NAIL FIN INSTALL:
- M13404 - L-ANGLE (QTY. 2)
- MPS-8X1 1/2 - FASTENERS (QTY. 4)
- PARTS FOR NAIL FIN INSTALL:
- M22127 - Z-CLIP (QTY. 2)
- M23616 - H450 Z-CLIP (QTY. 2)

**MUST BE USED WITH STANDARD
3 1/4" RECEPTOR & SUBSILLS**

SCALE 1:2

Our products are tested to the standards of and certified by some of the foremost organizations in the fenestration industry.





ALUMINUM 2 3/8" FRAME STACK MULLIONS

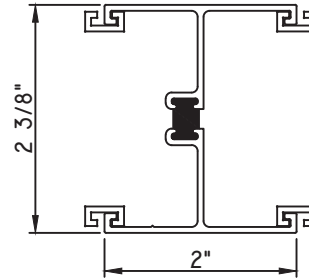

STACK MULL

MAX1700 - STACK MULL
M6270 - C-MULL (QTY. 2 OR 4)

FACTORY APPLIED INSTALL ONLY

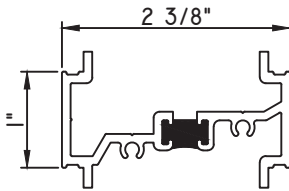

1" STACK MULL

MW25615 - STACK MULL
970-300 - WEEP COVER

FIELD APPLIED INSTALL ONLY

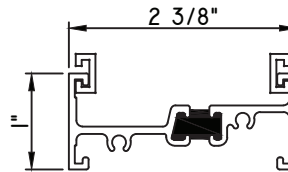

1" STACK MULL

M43325 - STACK MULL
QWP-43325 - END DAMS (QTY. 2)
BRBTT46 - POP RIVET (QTY. 4)
970-300 - WEEP COVER

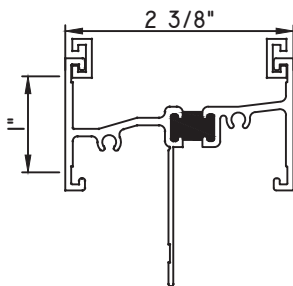

1 3/8" STACK MULL

MW23712 - STACK MULL
QWP-070706 - END DAMS (QTY. 2)
BRBTT46 - POP RIVET (QTY. 4)
970-300 - WEEP COVER

FACTORY APPLIED INSTALL ONLY

SCALE 1:2

Our products are tested to the standards of and certified by some of the foremost organizations in the fenestration industry.



ALUMINUM 2 3/8" FRAME VERTICAL MULLIONS

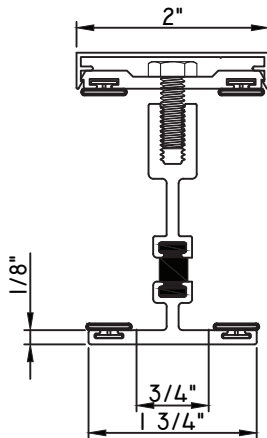

T-MULL

M16690 - T-MULL
 MAX17386 - BASE
 MAX14141 - CAP
 BPN-9159 - W.S. (QTY. 4)
 MH1/4 20X3/4 - BOLTS (18" APROX. O.C.)
 M13404 - L-ANGLE (QTY. 2)
 MPS-8X1 1/2 - FASTENERS (QTY. 4)

**MUST BE USED WITH STANDARD
 2 3/8" RECEPTOR & SUBSILL**

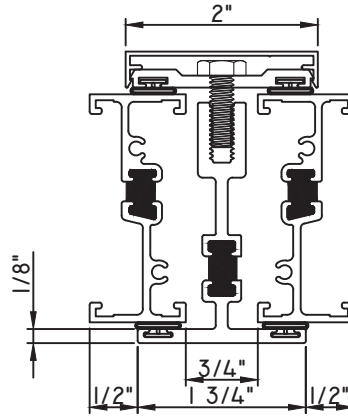

T-MULL/1" STACK LEFT/RIGHT

M16690 - T-MULL
 MAX17386 - BASE
 MAX14141 - CAP
 1" STACK MULL - M43325 LEFT/RIGHT
 BPN-9159 - W.S. (QTY. 4)
 MH1/4 20X3/4 - BOLTS (18" APROX. O.C.)
 M13404 - L-ANGLE (QTY. 2)
 MPS-8X1 1/2 - FASTENERS (QTY. 4)

**MUST BE USED WITH STANDARD
 2 3/8" RECEPTOR & SUBSILL**

SCALE 1:2

ALUMINUM 2 3/8" FRAME VERTICAL MULLIONS

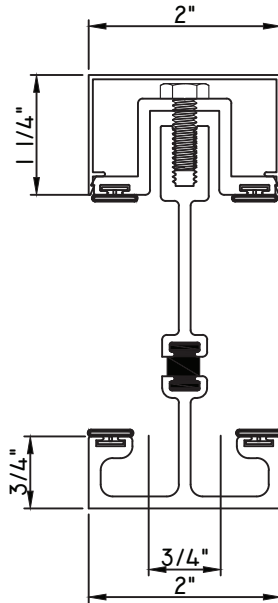

T-MULL

M536203 - T-MULL

M14895 - BASE

M14896 - CAP

BPN-9159 - W.S. (QTY. 4)

MH1/4 20X3/4 - BOLTS (18" APROX. O.C.)

M13404 - L-ANGLE (QTY. 2)

MPS-8X1 1/2 - FASTENERS (QTY. 4)

**MUST BE USED WITH STANDARD
2 3/8" RECEPTOR & SUBSILL**

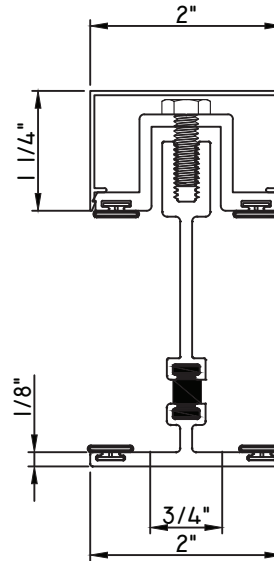

T-MULL

M16875 - T-MULL

M14895 - BASE

M14896 - CAP

SCALE 1:2